

**I. SCOPE AND INTENT:**

This technical specification is designed to provide engineers with guidelines for visual criteria, dimensional tolerances, as fired capabilities, and design considerations to ensure that parts are manufactured to meet your design criteria and be cost effective.

Typical design criteria follows:.

**II. DESIGN CRITERIA:**

The following design standards represent factors that should be considered to ensure optimal product design and material selection.

**A. Material selection**

CoorsTek offers a variety of materials to meet the specific requirements for your application. If you need assistance in selecting the appropriate material for your application, please contact your CoorsTek Sales Representative.

**B. Capabilities and Tolerances**

After the sintering process, the ceramic material is referred to as being in the “as-fired” state. For precision tolerances, fine surface finish, and superior flatness, post fire grinding may be required. Dimensional tolerances should only be specified as precise as is necessary to facilitate assembly and optimum performance.

**III. AS- FIRED DIMENSIONAL TOLERANCE:**

The following are typical “as-fired” dimensional capabilities and will apply unless otherwise specified by customer drawing or specifications given at the time of the quotation.

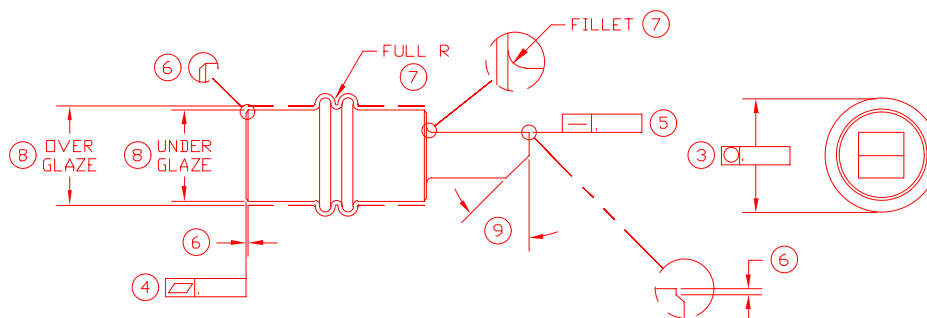

1. Alumina: For all parts smaller than 10” (254mm) all dimensions will be +/- 1% or +/- 0.005” (.12mm) whichever is greater (W.I.G.) Parts which have dimensions larger than 10” (254mm) will have dimensions toleranced +/- 1.5% or +/-0.010” (.25mm) (W.I.G.)
2. Zirconia: +/- 1.5% not less than +/-0.010” (.25mm).
3. Circularity (roundness): Will not exceed the dimensional tolerance.
4. Flatness: Faces will be flat within 0.006 “/” (mm/mm).
5. Straightness: Will apply to edges, rods, tubes and be 0.006 “/” (mm/mm).
6. Edges: May be up to 0.040” (1mm) break, either as a radius or as a 45 +/- 5 degree chamfer; tooling flats will not exceed 0.006” (.15mm).

7. Fillets: May be up to 0.040” (1mm). This is measured at the maximum extension from the perpendicular surface. Groove fillets can be up to a full radius. Fillets will exist independent of the features intersected.
8. Glaze: Features which are glazed will be measured dimensionally prior to the application of the glaze (“dimensions under glaze”). Typical glaze thickness is dependent on part design and can vary from 0.004” (.1mm) to 0.032” (.8mm). Glaze will typically pullback from a sharp edge up to 0.040” (1mm). Tolerances for glaze length or width are typically +/- 0.063” (1.5 mm).
9. Angles: Angular tolerances are +/- 2 degrees.

**IV. GROUND TOLERANCES:**

If tighter dimensional control is necessary than the tolerance for as-fired dimensions please discuss your requirements with your CoorsTek Sales Representative.







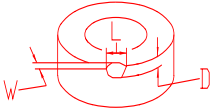

When geometric tolerances are used, ANSI standard Y14.5M will apply.

In cases where a feature or group of features has double dimensions, the one with the most tolerance will be chosen as a print dimension, while the second will be listed as “reference” only. If a feature lacks a dimension needed to define it, CoorsTek will request the customer to provide a revised print prior to quotation.

**V. VISUAL CRITERIA:**

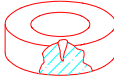
The following minimum visual criteria will be provided by CoorsTek unless otherwise specified:

9/1/98

<u>IMPERFECTION</u>	<u>VISUAL SAMPLE</u>	<u>ACCEPTANCE CRITERIA</u>
<p><b><u>BLEMISH:</u></b> Stained or discolored area attributable to normal composition and/or forming.</p>		0.060" (1.52 mm) maximum
<p><b><u>CHIP:</u></b> Open: area along edge or corner where material has been broken off. Closed: fractured area along edge or corner where material has not been broken off.</p>		Open and closed chips not to exceed 0.045" width X 0.045" depth X ULL. (0.045" = 1.14 mm) (ULL = unlimited length)
<p><b><u>CRACK:</u></b> Line of fracture without complete separation, to the unaided eye.</p>		None allowed.
<p><b><u>EXCESS MATERIAL:</u></b> Protrusion on a surface.</p>		Acceptable as long as within dimensional tolerances.
<p><b><u>FLASH/FIN:</u></b> Fine feather protrusion along a surface edge.</p>		Permitted on chamfer or radiused edge areas as long as it is not extending outside of the dimensional envelope.
<p><b><u>FOREIGN PARTICLE:</u></b> Particles of foreign material adhering to a surface.</p>		None allowed.
<p><b><u>HOLES - PITS:</u></b> Voids that extend into the surface.</p>		0.045" (1.14 mm) maximum in any direction that can be measured.
<p><b><u>INCLUSION:</u></b> Foreign material imbedded in the ceramic or a stain other than from normal composition and/or forming.</p>		0.060" (1.52 mm) diameter maximum.
<p><b><u>POROUS:</u></b> An area that retains dye penetrant, and if sectioned at the porous area, will show evidence of dye penetration into the body.</p>		None allowed.
<p><b><u>SURFACE MARKS:</u></b> (Scratches, score marks, grind marks) Long, narrow or shallow grooves cut into the surface.</p>		Not to exceed dimensional requirements.